

**U-R-B-A-N**

Trust. Right from the start!

# GLS 102 / GLS 200/S

Glazing bead saw



**GLS 102**



**GLS 200/S**

# Our know-how is your advantage

## GLS 102 with manual feed / GLS 200/S with automatic feed + glass simulation

With our bead saws GLS 102 and GLS 200/S for cutting two pvc beads in an angle of 45° we developed for you two very robust and flexible machines that are easy to maintain. Additionally they convince by their price-performance ratio and optimally meet your productional requirements. The GLS 102 as well as the GLS 200/S are equipped with two powerful three-phase motors each 0,75 kW and four pneumatic clamping cylinders with white rubbered pressure pads in order to avoid dents and marks at the beads. Clamping sequence freely eligible with switch (only at GLS 200/S). At the guide carriage wiper rings ensure that no residuals get into the bearing and the ball bushings. This prolongs the saw's life in your production.

Generally with both machines you can cut two beads at the same time. With the GLS 200/S we even offer the option to cut four beads in one working step. This guarantees efficiency and helps to save valuable production time while the automatic feed ensures constantly high machining quality. Additionally the GLS 200/S is equipped with a glass simulation unit with 10-fold turret stop simulating the clamping of the beads in glazed state. The saw blades are included in the scope of delivery.

### Options:

- exhausts URB 2200-2 (compellable necessary for GLS 200/S)
- exhaust device for GLS 102
- profile-dependent limiters
- profile support: 3 m or 6 m
- manual measuring device 1,5 m and 3 m
- electronic servo length stop
- frequency converter for speed (for GLS 200/S)









GLS 102 with clamping unit, vertical and standard fixture (incl.)

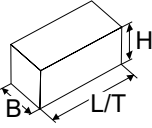

GLS 200/S profile support with steplessly adjustable glass simulation (illustration with fixture-not included in extend of delivery).

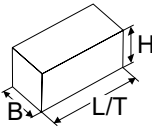

GLS 102 with measuring feeler 1.5 m and profile support 3 m (also available with 6 m).  
Small picture, left side: measuring feeler 3 m. Small pricture, right side: servo-length stop.

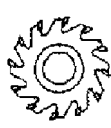
 <p>GLS 102 - 175 kg GLS 200/S - 179 kg</p>	 <p>GLS 102 L/T = 1075 mm B = 510 mm H = 1040 mm</p>	 <p>6 - 8 bar</p>	 <p>GLS 102 = HSS GLS 200/S = HM D = 200 mm d = 32 mm</p>
 <p>230 / 400 V 50 - 60 Hz L1-L2-L3-N-PE 1,5 kW</p>	 <p>GLS 200/S L/T = 975 mm B = 685 mm H = 1205 mm</p>	<p>2x</p>  <p>0,75 kW 2800 1/min.</p>	 <p>GLS 102 = HSS GLS 200/S = HSS D = 103 mm d = 32 mm 1x left, 1x right,</p>

Urban Machinery • 125 Werlich Drive • Cambridge, ON, N1T 1N7  
Tel.: (519) 624-0080 • Fax: (519) 624-8588 • e-mail: sales@urban-machinery.com

Visit us on the World Wide Web @ <http://www.u-r-b-a-n.com>

Subject to change without notice • Printed in Canada 2015 • Technical data is valid for machinery without options